

Arktis Laser Product Datasheet

LMS-BY01 Combined Dual-Wavelength Laser System

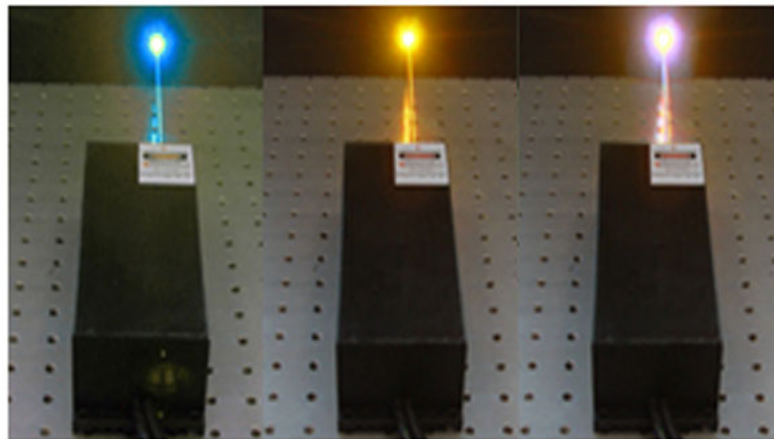

Series Specifications:

Nominal Wavelength	473 nm, 593.5 nm
Output Type	CW
Laser Source Type	DPSS

Overview:

The LMS-BY01 Series of Combined-wavelength Diode-Pumped Solid-State (DPSS) Lasers are specifically designed for the field of optogenetics research. This blue/yellow laser system is available with 80 mW combined output, and each wavelength can be modulated at speeds of up to 30 kHz. The wavelengths of this laser are specifically chosen for use with the microbial opsins most commonly used in optogenetics research. (Channelrhodopsin, Halorhodopsin, etc.)

The driver is available as a complete FDA-compliant system or as an O.E.M. component with significantly reduced dimensions. Upon request, this laser can be coupled directly to an optical fiber, or provided with an FC/PC or SMA fiber coupler so you can use your existing optical fiber.

Key Features:

- Specially designed for use in optogenetics research
- Air cooled - no need for water cooling or external chiller
- Lightweight, compact design
- Efficient DPSS technology runs on standard AC power (85 - 264 V, 47 - 63 Hz)
- >10,000 hours continuous maintenance-free operating life
- TTL and Analog modulation (input via BNC connector) up to 30 kHz
- Adjustable output power via lockable dial
- LED display showing LD current, laser cavity temperature
- FDA CDRH Compliant Class IIIb / Class IV enclosure
- 48-hour replacement coverage available for an additional fee on specific models

Package Includes:

- Laser Head
- Driver/Power Supply
- Power Cable
- BNC Connector (LabSpec models only)
- Keys, Safety Interlock
- Hard-shell Carrying Case

Specifications:

This spec sheet has been generated specifically for part number M24-3, per your request. Each column represents the specifications of the individual component lasers that make up the multi-wavelength system.

Component Laser Wavelength (nm)	473	593.5
Output Power (mW)	>50	>50
Output Power Stability (%RMS/4h)	<5	<5
Divergence (mrad, full angle)	<1.5	<2
Beam Dimensions (mm, 1/e ²)	1.2	3
M ²	<1.2	<1.5
Max. Analog Modulation Freq. (Hz)	150	150
Max. TTL Modulation Freq. (Hz)	150	150
Modulation Input Signal	0-5 VDC	0-5 VDC
Total Power Consumption (W)	20	80
Max. Power Input Duty Cycle	100%	100%
Standard Warranty (months)	12	12
MTTF (operational hours)	10000	10000

CW: All specifications are based on performance at full output power and after the specified warmup period. Output characteristics may change if the laser is run at a different power level.

Q-Switched: Specifications are based on the laser pulsing at the specified design frequency. Output characteristics may change if the laser is run at a different frequency.

Power Supply Options:

These lasers are available with several different power supply options. The model that you have selected is highlighted below, and any other options are shown for easy reference.

	Power Supply Type:	FM	FF
FDA-Compliant LabSpec 	Input Power	85v to 264v	85v to 264v
	Power Supply Weight (kg)	1.5	2.6
	Dimensions (mm)	154 (l) x 155 (w) x 95 (h)	268 (l) x 145 (w) x 106 (h)

Multi-wavelength lasers include a separate power supply for each wavelength. In some cases the power supply for each wavelength may be slightly different in size. If the dimensions of the power supply are a concern for you please inquire with us before placing your order.

*Power supply may not be exactly as shown, see dimensional drawings on next 2 pages.

*Dimensions for fiber-integrated (I_) include laser head packaged inside.

Regulatory Classification:

The model you have selected (M24-3) requires the following safety label(s):

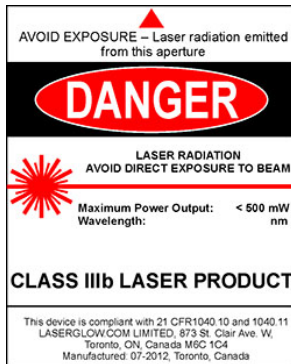

Dimensional Drawing - Laser Form Factor: 3:

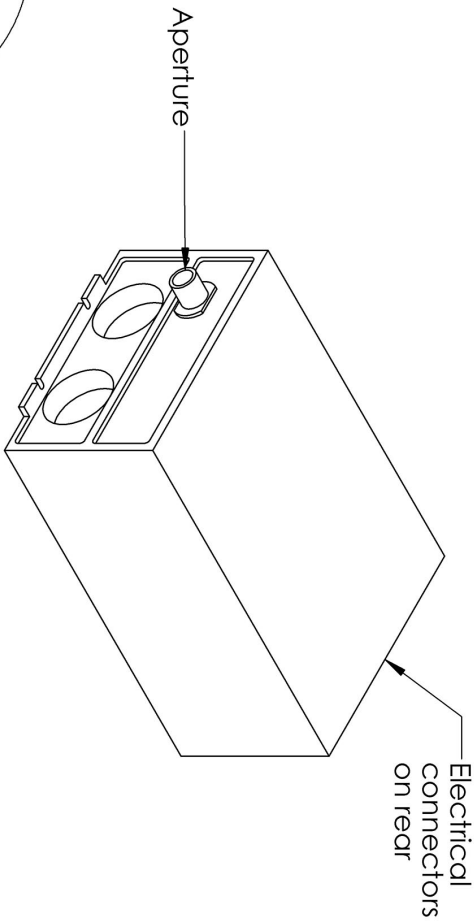
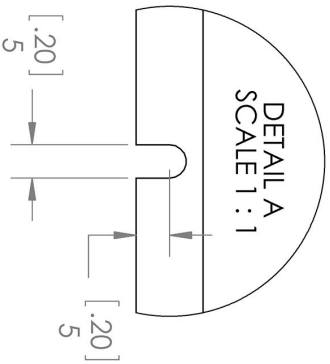
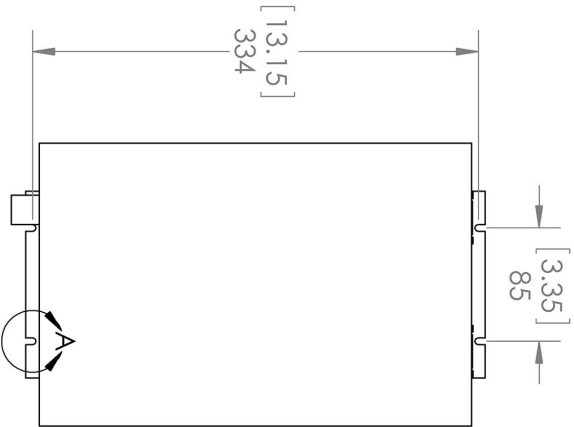
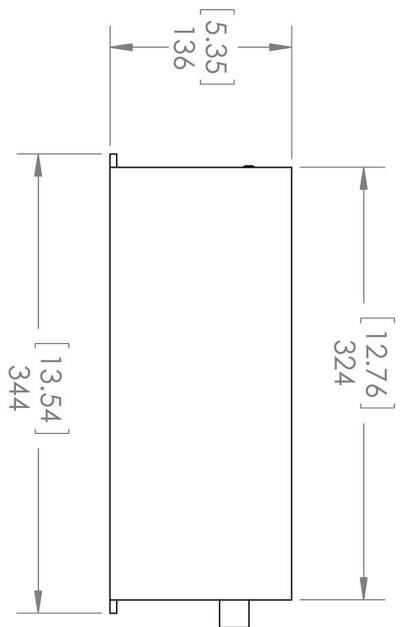
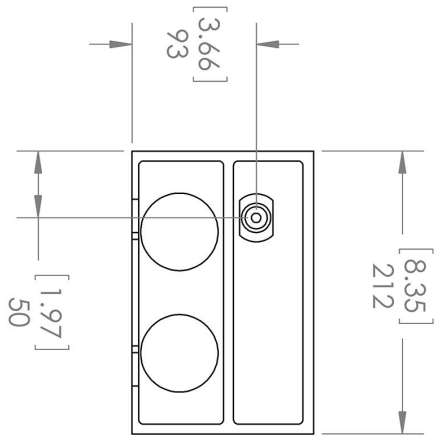

<p>UNLESS OTHERWISE SPECIFIED: DIMENSIONS ARE IN MM(INCH) TOLERANCES: +/- 0.75 MM</p>		<p>TITLE: Lab/OEM 3 Housing</p>
<p>THE INFORMATION CONTAINED IN THIS DRAWING IS THE SOLE PROPERTY OF LASERGLOW TECHNOLOGIES. ANY REPRODUCTION IN PART OR AS A WHOLE WITHOUT THE WRITTEN PERMISSION OF LASERGLOW TECHNOLOGIES IS PROHIBITED. © 2012 LASERGLOW.COM LIMITED. ALL RIGHTS RESERVED</p>		<p>REV 1</p>
<p>SCALE: 1:5</p>	<p>SHEET 1 OF 1</p>	<p>Laserglow Technologies</p>

Dimensional Drawing - Power Supply Form Factor: FM:



UNLESS OTHERWISE SPECIFIED:
 DIMENSIONS ARE IN MM(INCH)
 TOLERANCES: +/- 0.75 MM

THE INFORMATION CONTAINED IN THIS
 DRAWING IS THE SOLE PROPERTY OF
 LASERGLLOW TECHNOLOGIES. ANY
 REPRODUCTION IN PART OR AS A WHOLE
 WITHOUT THE WRITTEN PERMISSION OF
 LASERGLLOW TECHNOLOGIES IS
 PROHIBITED. © 2012 LASERGLLOW.COM
 LIMITED. ALL RIGHTS RESERVED

Laserglow Technologies

TITLE:

Power Supply
FM/FR





REV
1

SCALE: 1:3

SHEET 1 OF 1

Accessories:

The most popular accessories for model M24-3 are shown below. For additional details regarding these or other accessories please see our website or contact us directly.

Part Number	Description	
 ACS VISHXA	SMA-905 Fiber Coupler/Collimator for visible spectrum wavelengths (400 to 700 nm) (installed and aligned) 11mm diameter input lens Full Details: www.arktislaser.com/ACS	
 ACF VISHXA	FC/PC Fiber Coupler/Collimator for visible spectrum wavelengths (400 to 700 nm) (installed and aligned) 11mm diameter input lens Full Details: www.arktislaser.com/ACF	
 ACALB237X	Carrying Case-107 Holds Lab/OEM 2/3 wavelength Labspec laser Full Details: www.arktislaser.com/ACA	Included With Laser
 AFS2002XX	Armored Fiber With SMA 905 Connectors 200um Core Multimode 2 m length Full Details: www.arktislaser.com/AFS	
 AFF2002XX	Armored Fiber With FC/PC Connectors 200um Core Multimode 2m length Full Details: www.arktislaser.com/AFF	

FOR MORE INFORMATION PLEASE CONTACT:

Arktis Laser
112 Elizabeth St, Unit 5-331, Toronto, ON, Canada M5G 1P5
Tel. 1-416-886-1178 Fax 1-647-874-7129
sales@arktislaser.com www.arktislaser.com

E&OE: Data included in this sheet may be subject to change without notice.

Please confirm critical specifications with our staff prior to ordering.